

Handshower Accessory

FEATURES:

- All brass construction
- Available in all finishes. Warranty varies according to finish
- Meets: ASME A112.18.1-2005 / CSAB 125.1-2005

Swivel Wall Bracket
with Waterway
18.10.013

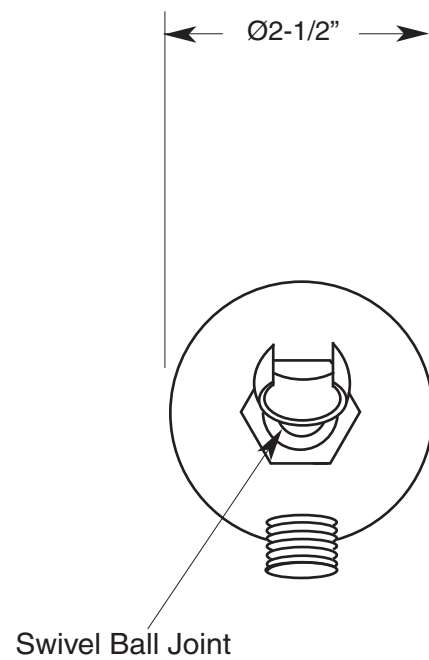
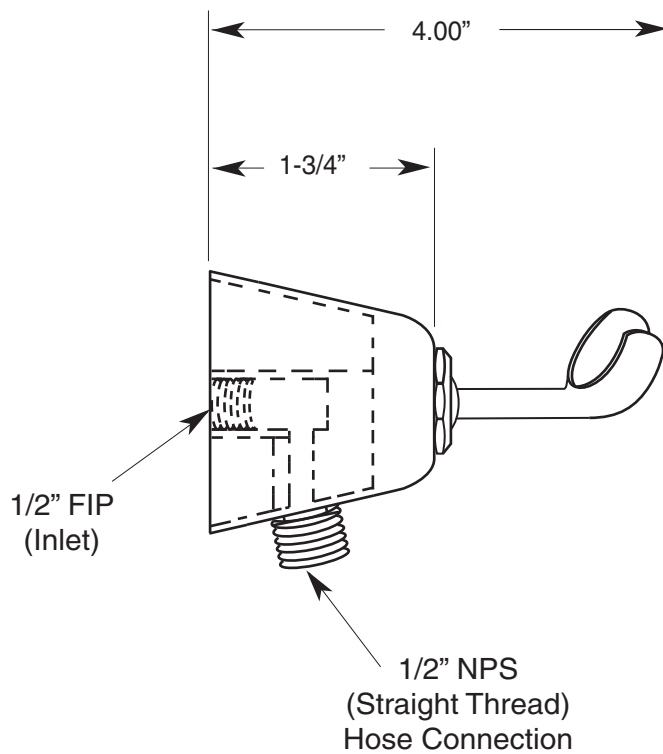

Note: Measurements are subject to change or cancellation. No responsibility is assumed for use of superseded or voided pages.