

Features:

- Forged brass construction
- Ceramic disk valve cartridge 18.30.865
- Adjustable hot limit safety stop
- Reversible cartridge
- 5.6 GPM @ 45 PSI
- Meets: ASME A112.18.1-2005/CSAB125.1-2005

SPECIFICATIONS
Pressure Balance Tub & Shower
Valve & Trim
1.202068
Toronto Handle
(1.202068T Trim Only)

Cutaway View

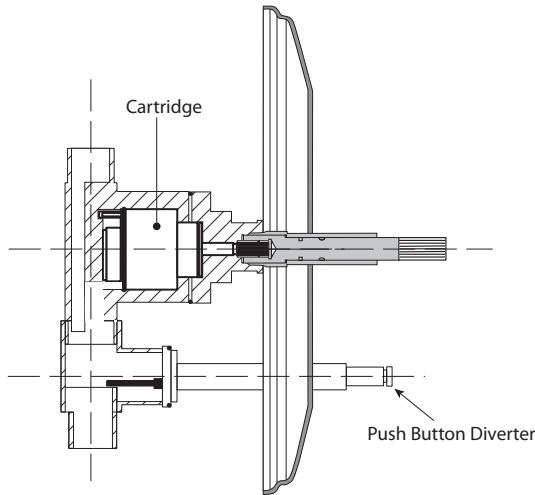

Top View

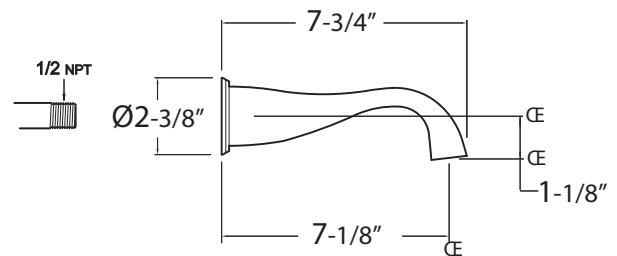
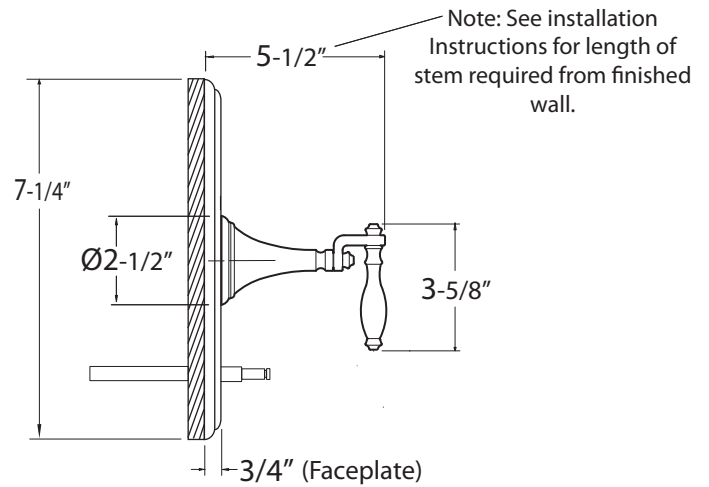
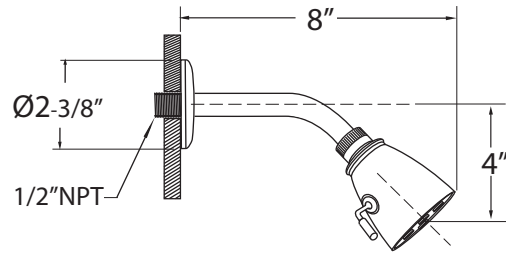
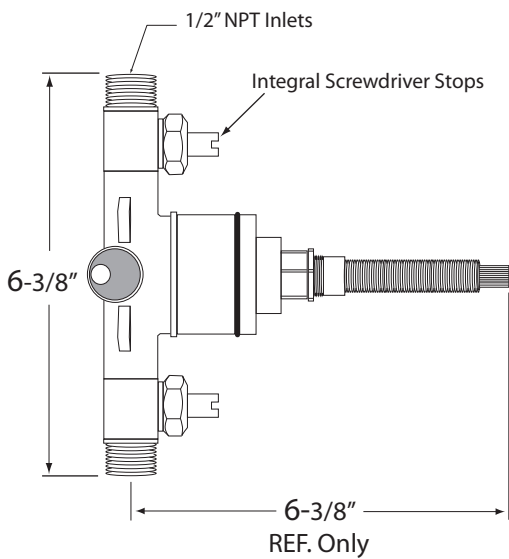

Note: Measurements are subject to change or cancellation. No responsibility is assumed for use of superseded or voided pages.