

Features:

- Forged brass construction
- Built-in diverter valve assembly
- 8" Center to Center available on request
- Replacement cartridge: 18.30.035 - cold / 18.30.036 - hot
18.30.012 - diverter
- Certified to meet or exceed the following codes and standards:
ASME A112.18.1/CSAB 125.1-2011

SPECIFICATIONS
3 Valve Tub & Shower

Valve & Trim

1.202033

Toronto Handle

(1.202033T Trim Only)

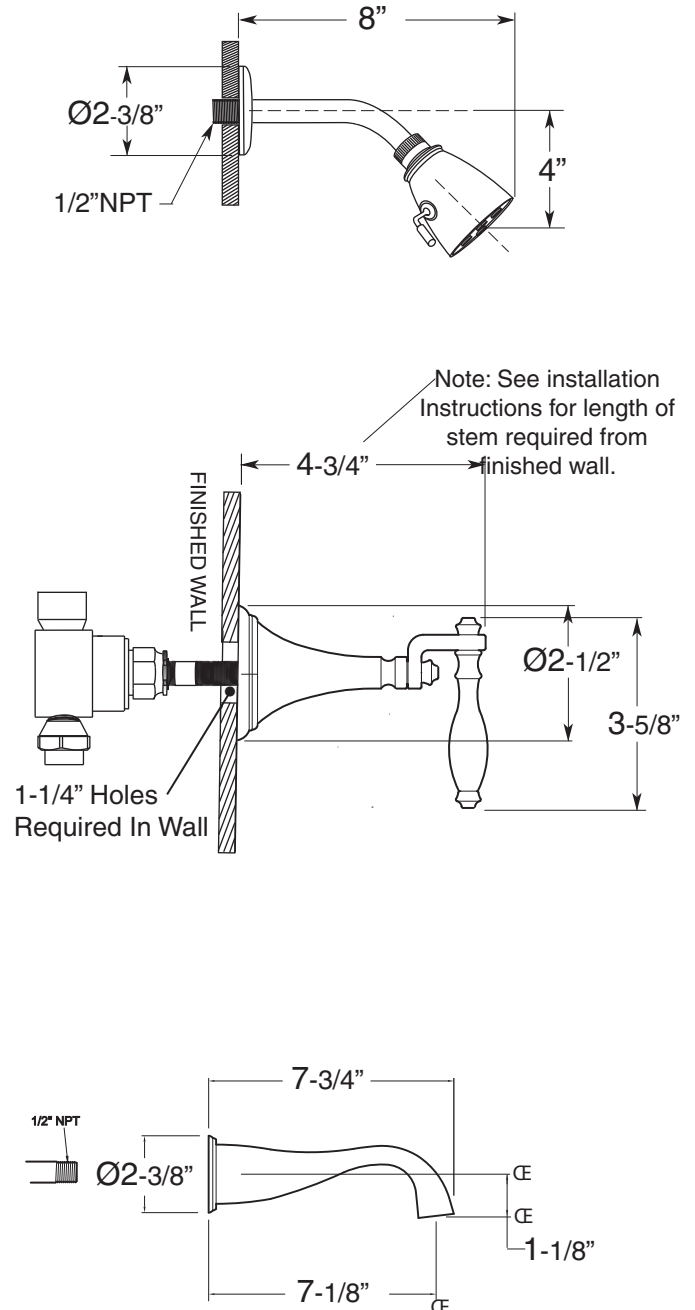
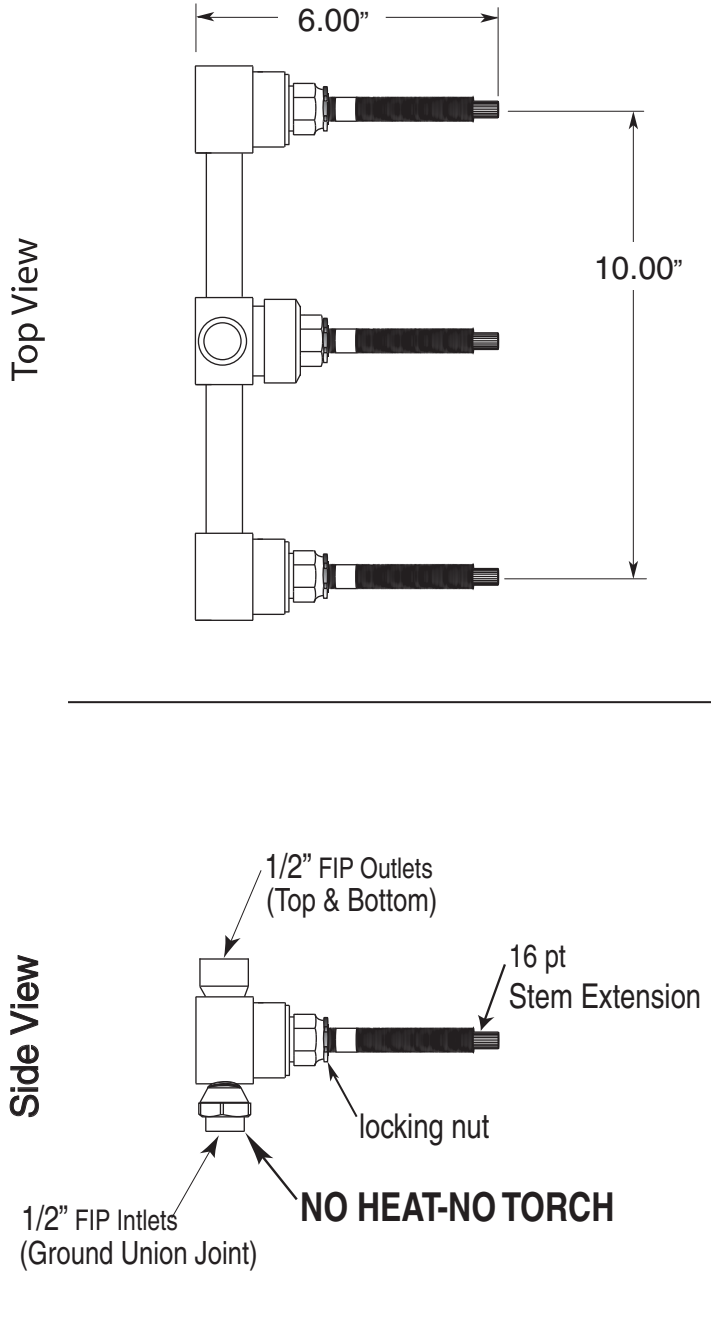

Note: Measurements are subject to change or cancellation. No responsibility is assumed for use of superseded or voided pages.