

**FEATURES:**

- Forged brass construction.
- Thermostatic valve cartridge: 18.30.082
- Shut-off cartridge: (1) 18.30.036
- Screw driver spring check valve: (2) 18.30.181
- 14.5 GPM @ 45PSI (9.5 top exit)
- Meets: ASME A112.18.1/CSA B125.1-2012

**1/2" Thermostatic**

**One Volume Control  
Valve & Trim  
1.070896.V1  
Stella X Handle**

**(1.070896.V1T - Trim Only)**

**SIDE VIEW - INSTALLED**

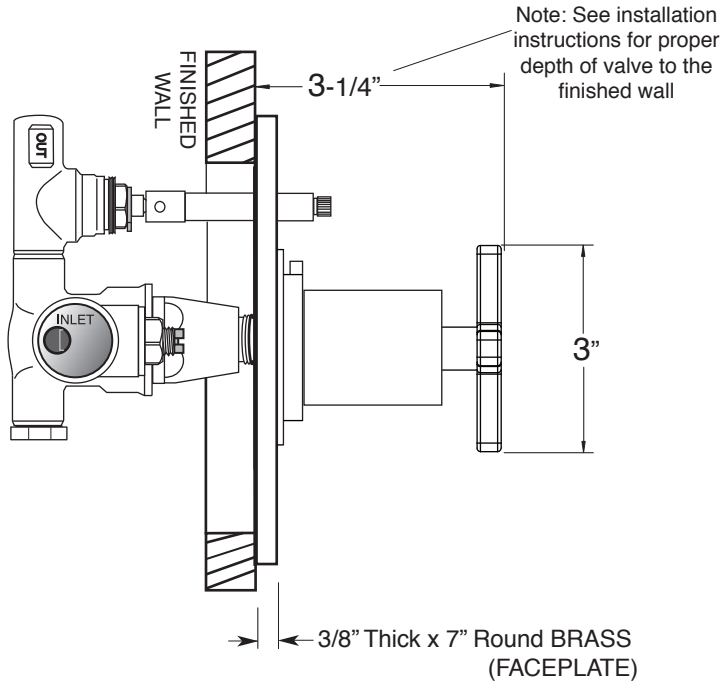

**SIDE VIEW - VALVE ONLY**

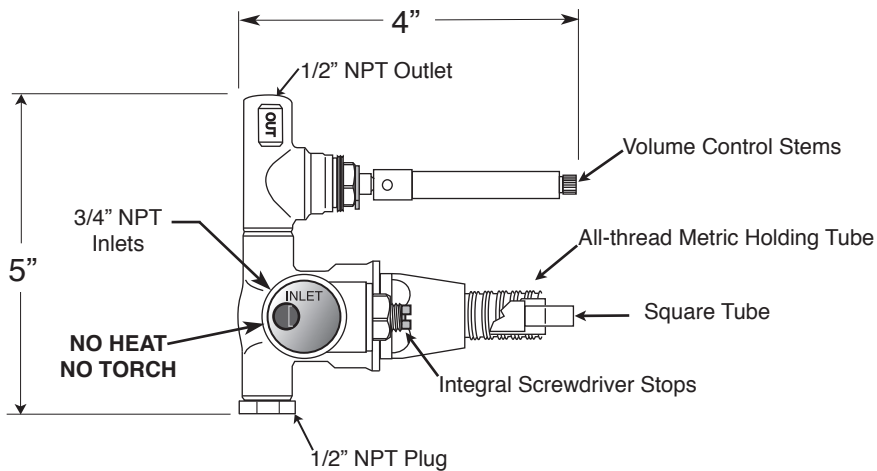

Note: Measurements are subject to change or cancellation. No responsibility is assumed for use of superseded or voided pages.