

**FEATURES:**

- Forged brass construction.
- Thermostatic valve cartridge: 18.30.082
- Screw driver spring check valve: (2) 18.30.181
- 14.5 GPM @ 45PSI (9.5 top exit)
- Certified to meet or exceed the following codes and standards:  
ASME A112.18.1/CSAB 125.1-2012

**1/2" Thermostatic**

No Volume Control  
Valve & Trim  
1.058096.V0  
Maya Handle

(1.058096.VOT Trim Only)

Note: Separate shut-offs required to operate system.

**SIDE VIEW - INSTALLED**

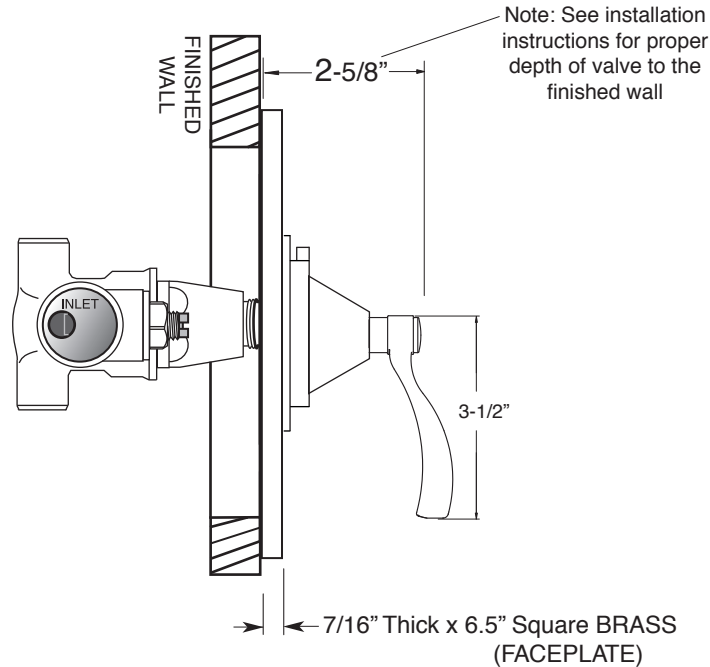

**SIDE VIEW - VALVE ONLY**

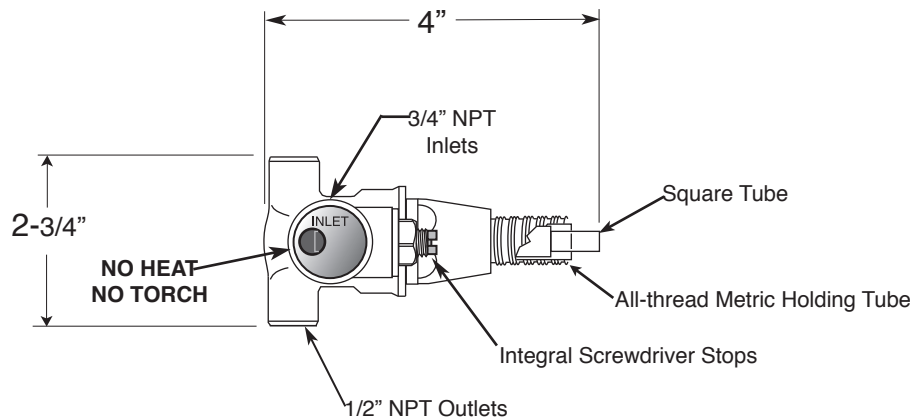

Note: Measurements are subject to change or cancellation. No responsibility is assumed for use of superseded or voided pages.