

1/2" Thermostatic

No Volume Control

Valve & Trim

1.005396.V0

Regent Handle

(1.005396.V0T - Trim Only)

FEATURES:

- Forged brass construction.
- Thermostatic valve cartridge: 18.30.082
- Screw driver spring check valve: (2) 18.30.181
- 14.5 GPM @ 45PSI (9.5 top exit)
- Meets: ASME A112.18.1/CSA B125.1-2012

Note: Separate shut-offs required to operate system.

SIDE VIEW - INSTALLED

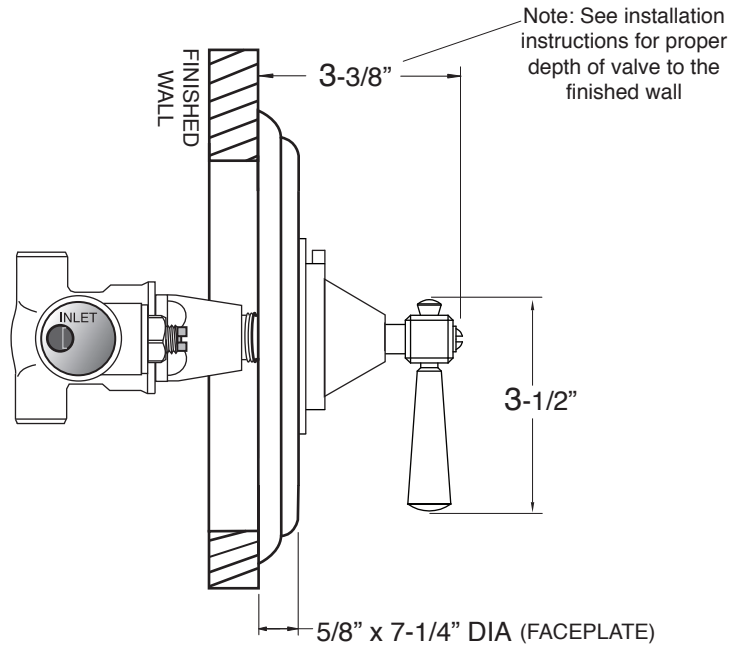

SIDE VIEW - VALVE ONLY

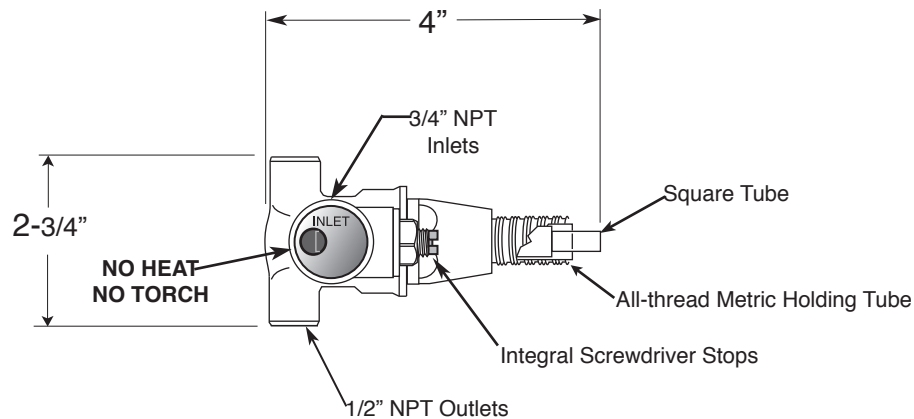

Note: Measurements are subject to change or cancellation. No responsibility is assumed for use of superseded or voided pages.