

FEATURES:

- Certified to meet or exceed the following codes and standards:
ASME A112-18.1 / CSA B125-1-2011
- Replacement cartridge P/N: 18.30.036

1/2" In-Line Shut-Off

Valve & Trim

1.000687

Portsmouth Handle

(1.000687T - Trim Only)

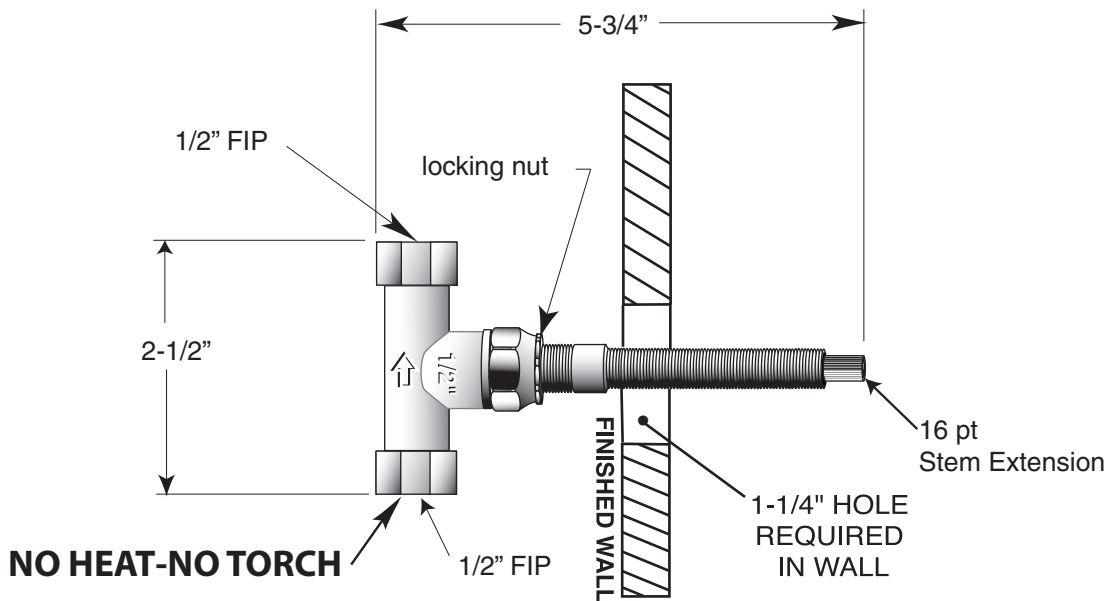
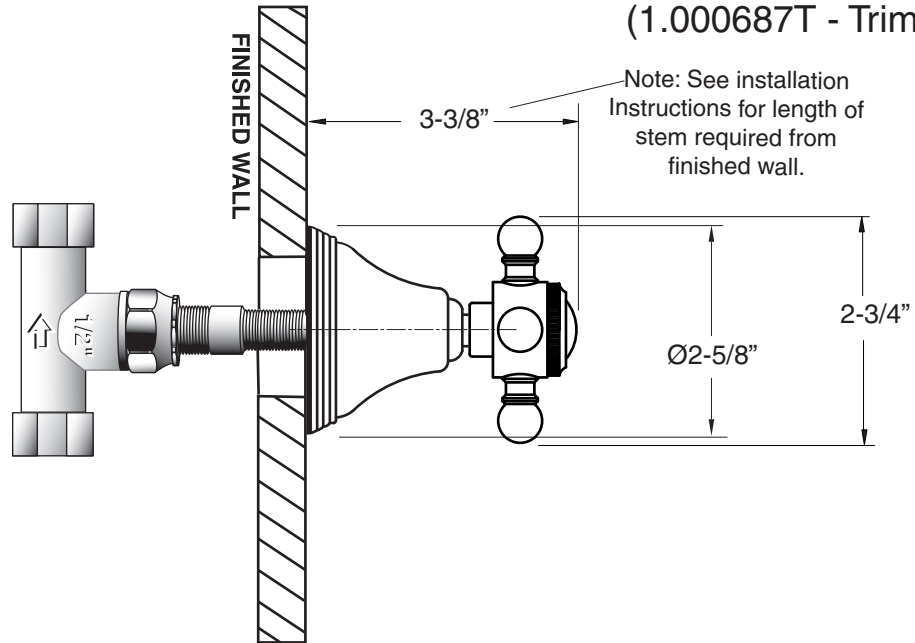

Note: Measurements are subject to change or cancellation. No responsibility is assumed for use of superseded or voided pages.