

Rite-Temp® | K-8304-PX

Pressure-balancing valve body and cartridge kit with PEX crimp connections

Features

- Includes valve body, pressure balance cartridge, rough-in guide, and mudguard
- 1/2" PEX Crimp (F1807 style) inlets
- 1/2" Universal NPT & direct sweat outlets
- 5.0 gpm (18.9 lpm) maximum flow rate at 45 psi (3.1 bar)
- Single lever design cycles from off through cold to hot
- Antiscald protection
- One-piece cartridge design simplifies installation and maintenance
- Adjustable high-temperature limit stop to control maximum water temperature
- Requires valve trim to complete installation (sold separately)
- Pressure-balancing diaphragm technology maintains outlet temperature within +/-3°F during water pressure fluctuations



Available Colors/Finishes

Color tiles intended for reference only.

^{NA} NA Not Applicable



Codes/Standards

ASME A112.18.1/CSA B125.1
ASSE 1016/ASME A112.1016/CSA B125.16

Valves

Included Valves: Pressure Balance, Thermostatic

Shower Valve

Flow Rate Maximum @ 45 psi: 5 gpm (18.9 l/min)

Pressure: 45 psi (3.1 bar)

Maximum Static Pressure: 125 psi (8.6 bar)

Minimum Operating Pressure: 20 psi (1.4 bar)

Material

- Forged dezincification-resistant brass body provides long term reliability and resistance to aggressive water conditions
-

Warranty

See website for detailed warranty information.

KOHLER® Faucet Lifetime Limited Warranty



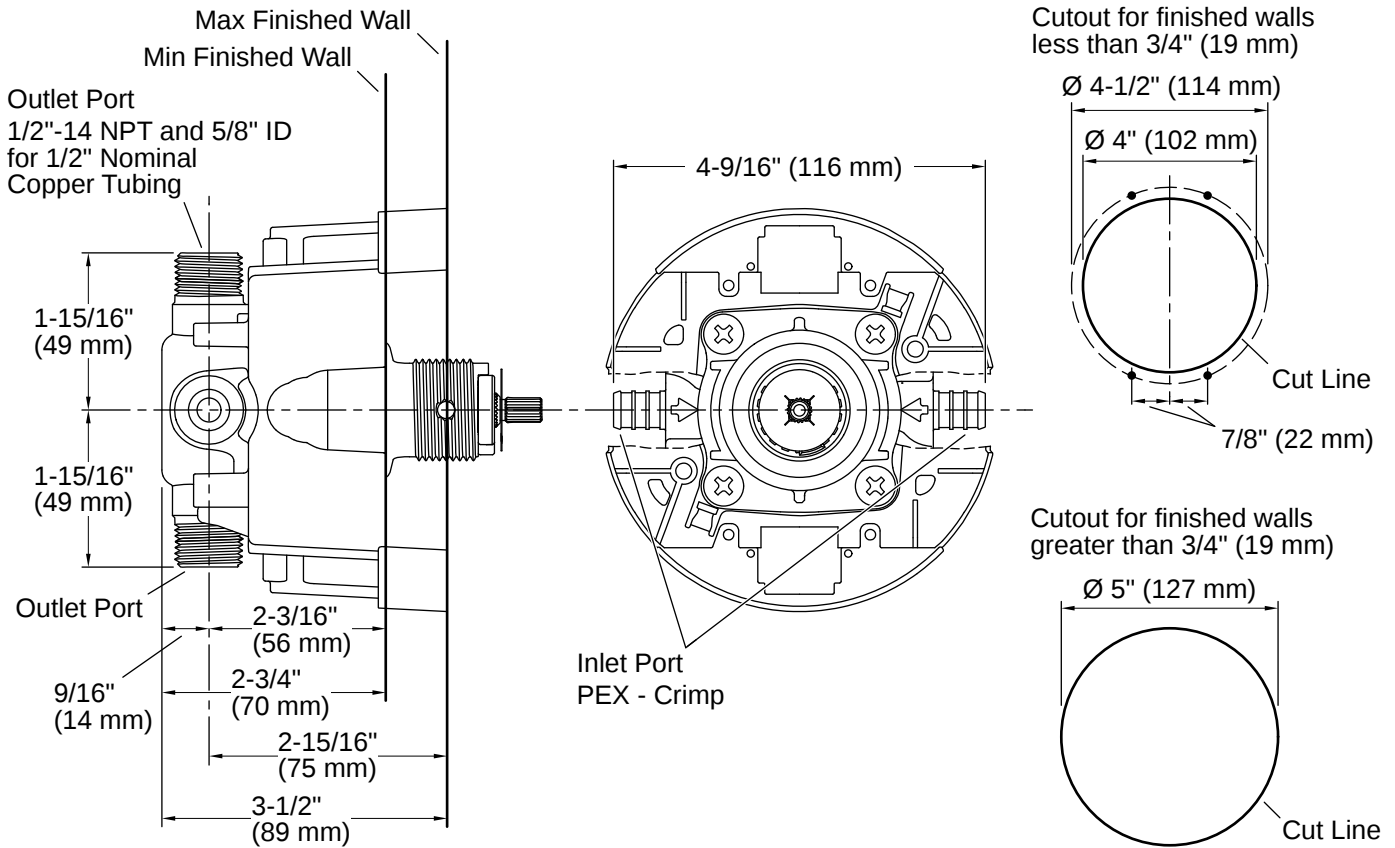

Installation

- Designed for use in standard, back-to-back, and thin wall installations
- Valve body features integral mounting locations and symmetrical valve inlets to simplify installation
- Cartridge is reversible for installations where hot and cold supplies are reversed
- Rough-in guide designed for both standard and thin wall installations
- Installed valve rough-in can be flushed and pressure-tested to 150 psi max (air or water) without cartridge by using test cap (sold separately)

Installation Notes

Install this product according to the installation instructions.

For use with showerheads or handsprays rated at 0 gal/min (0 l/min) or higher.
 Avoid cross-flow conditions. Do not install shut-off device on either valve outlet.
 Cap the shower outlet if deck-mount spout, diverter, or handshower is connected to the spout outlet.
 Install straight pipe or tube drop of 7" (178 mm) to 18" (457 mm) with single elbow between the valve and wall-mount spout.
 For finished walls greater than 3/4" (19 mm) and less than 1-1/2" (38 mm), install support(s) 2" (51 mm) from the stud face.
 For finished walls greater than 1-1/2" (38 mm), install support(s) 3" (76 mm) from the face of the finished wall.

