



Triton® Bowe® | K-630T40-4AG

Industrial exposed shower

Features

- 8" (203 mm) widespread faucet holes
- 1/4-turn full brass ceramic valve
- Includes Coralais® showerhead with 1.75 gal/min (6.6 l/min) maximum flow rate [max at 60 psi (4.14 bar)]; 30% more water saving than 2.5 gpm showerheads
- 2-7/16" vandal-resistant metal lever handles
- Drain sold separately



Sustainability



Available Colors/Finishes

Color tiles intended for reference only.

■ CP Polished Chrome



1-800-4KOHLER (1-800-456-4537)
Kohler Co. reserves the right to make revisions without notice to product specifications.
For the most current specification sheet, go to www.kohler.com USA or www.kohler.ca Canada.
4-15-2026 4:5 - US-CA

THE BOLD LOOK
OF **KOHLER**

Codes/Standards

None Applicable

Technical Information

All product dimensions are nominal.

Handle

Handle Style/ Type: Lever

Flow Rate

Shower/Rainhead Rated 1.75 gpm (6.6 l/min)
Maximum Flow:

Valves

Included Valve: Volume Control

Material

- Solid-brass construction for durability and reliability
-

Recommended Products/Accessories

K-23723 Faucet cleaner

Warranty

See website for detailed warranty information.

KOHLER® One-Year Limited Warranty



1-800-4KOHLER (1-800-456-4537)

Kohler Co. reserves the right to make revisions without notice to product specifications.

For the most current specification sheet, go to www.kohler.com USA or www.kohler.ca Canada.

4-15-2026 4:5 - US-CA

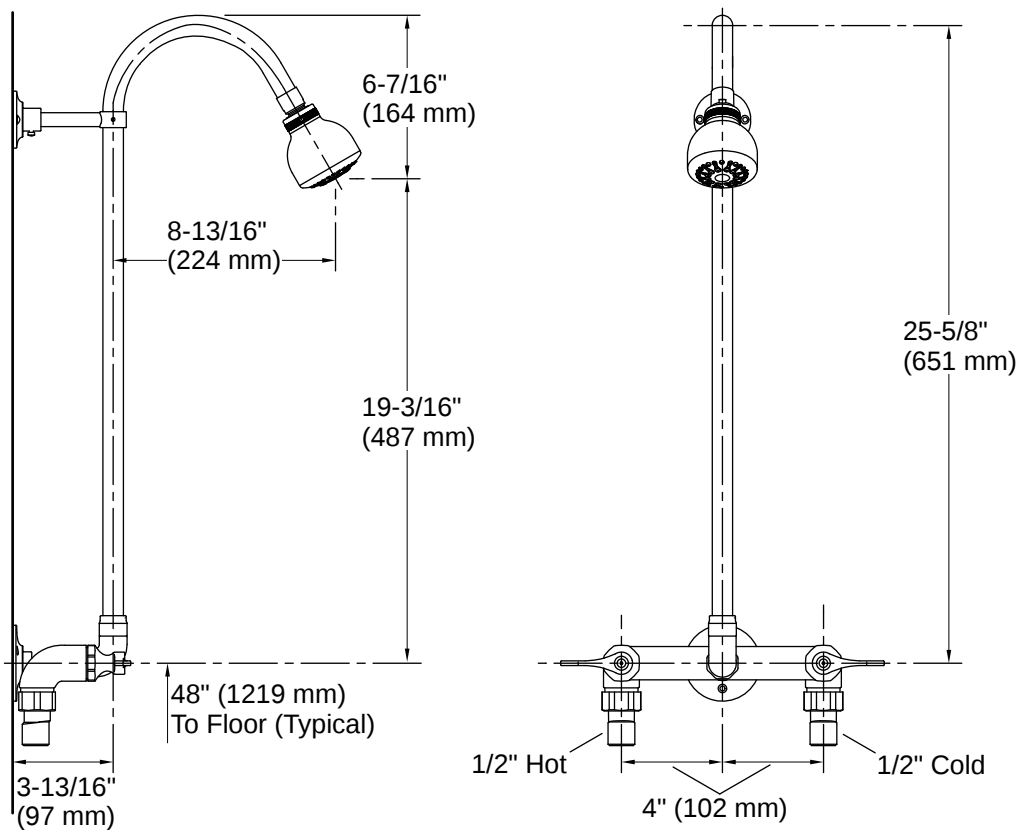

Installation Notes

Install this product according to the installation instructions.

For use with automatic compensating valves rated at 1.35 gal/min (5.1 l/min) or less.

