



# Steward® | K-4918

Half-stall waterless urinal

## Features

- Cartridge-free waterless urinal functionality
- Saves up to 40,000 gallons of water per fixture per year and significantly reduces sewage and maintenance costs
- Cartridge-free integral trapway provides enhanced performance and less maintenance
- Optimized interior design virtually eliminates splashing
- Touch-free design is vandal resistant and offers added hygiene to users
- This product can help a building earn Water Efficiency points in LEED® Green Building Rating System



## Available Colors/Finishes

*Color tiles intended for reference only.*

- 7 Black Black



1-800-4KOHLER (1-800-456-4537)  
Kohler Co. reserves the right to make revisions without notice to product specifications.  
For the most current specification sheet, go to [www.kohler.com](http://www.kohler.com) USA or [www.kohler.ca](http://www.kohler.ca) Canada.  
4-15-2026 3:50 - US-CA

THE BOLD LOOK  
OF **KOHLER**®

---

## Codes/Standards

*ADA compliant when installed to the specific requirements of these regulations.*

ADA

ASME A112.19.2/CSA B45.1

ADA

ICC/ANSI A117.1

---

## Technical Information

*All product dimensions are nominal.*

Spud size:	Inlet, None
Spud size:	2", Outlet, Rear
Trapway Type:	Concealed

---

## Material

- Vitreous china
- 

## Recommended Products/Accessories

1048656 Sealing liquid (1 Gallon)

1174866 3-Pack Waterless Urinal Cleaner

K-4929 Waterless urinal maintenance balls

---

## Warranty

*See website for detailed warranty information.*

KOHLER® One-Year Limited Warranty



1-800-4KOHLER (1-800-456-4537)

Kohler Co. reserves the right to make revisions without notice to product specifications.

For the most current specification sheet, go to [www.kohler.com](http://www.kohler.com) USA or [www.kohler.ca](http://www.kohler.ca) Canada.

4-15-2026 3:50 - US-CA

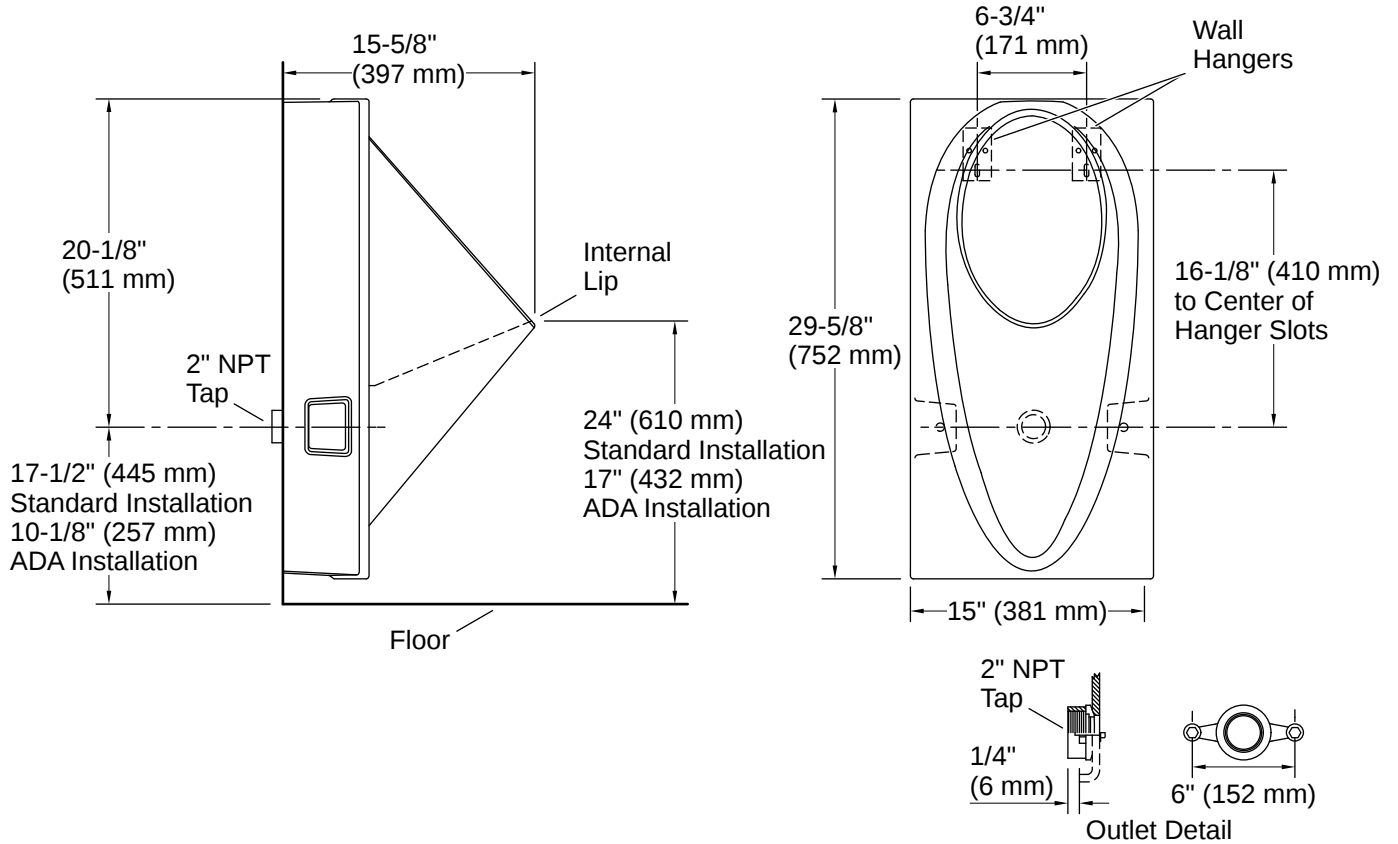

Installation

- 29-5/8" H x 15" W x 15-5/8" D

Installation Notes

*Install this product according to the installation instructions.*

CAUTION: Risk of property damage. When connecting waterless urinals to the building drain waste vent system, do not use copper pipe or copper tube connectors. The use of a copper connector will result in corrosion of the connector and potential building structure damage caused by leakage.

Product dimensions are nominal and may vary per ASME A112.19.2 tolerances.

ADA compliant when installed to the specific requirements of these regulations.

