



# Falling Water® | K-410-K

5/8" two-handle ceramic valve

## Features

- 2.2 gpm (8.3 lpm) maximum flow rate at 60 psi (4.14 bar)
- Dual-control wall-mounted
- KOHLER® ceramic disc valves exceed industry longevity standards for a lifetime of durable performance



## Available Colors/Finishes

*Color tiles intended for reference only.*

<sup>NA</sup> NA Not Applicable



1-800-4KOHLER (1-800-456-4537)  
Kohler Co. reserves the right to make revisions without notice to product specifications.  
For the most current specification sheet, go to [www.kohler.com](http://www.kohler.com) USA or [www.kohler.ca](http://www.kohler.ca) Canada.  
4-15-2026 1:8 - US-CA

THE BOLD LOOK  
OF **KOHLER**®

## Codes/Standards

ASME A112.18.1/CSA B125.1  
NSF/ANSI/CAN 372  
NSF/ANSI/CAN 61  
DOE - Energy Policy Act 1992

---

## Valves

Included Valve:                      Thermostatic Mixer

---

## Material

- Brass
- 

## Warranty

*See website for detailed warranty information.*

KOHLER® Faucet Lifetime Limited Warranty



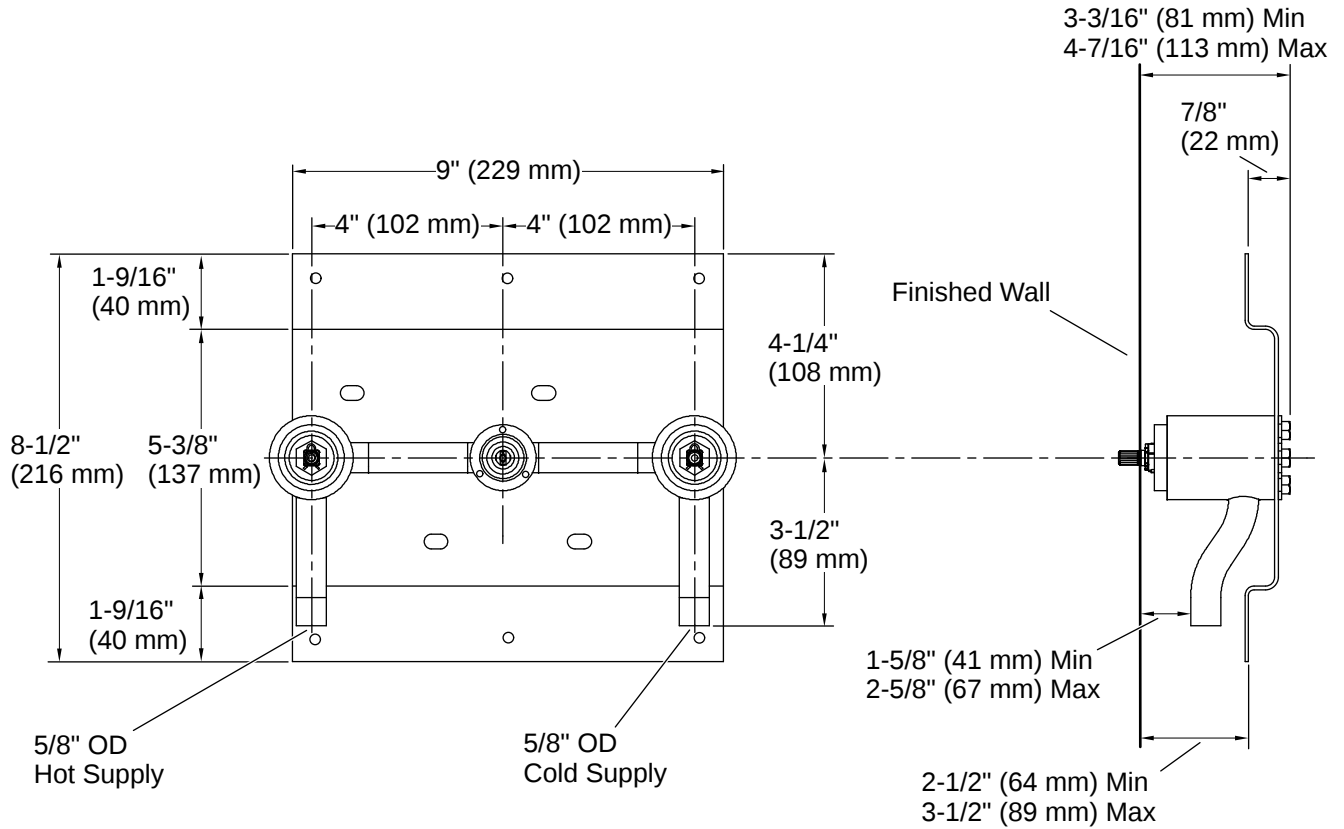

## Installation Notes

*Install this product according to the installation instructions.*

Three 1-5/8" (4.1 cm) diameter cutout holes are required for the spout and handles.

Follow the installation dimensions precisely as there is no deep roughing-in kit available for this product.

WARNING: Risk of property damage. For exterior wall installations, ensure proper wall insulation to prevent frozen pipes.

