



Aquifer®+ | K-29639

Hollow fiber membrane single replacement filter cartridge

Features

- For use with the K-29638 Aquifer®+ water filtration system
- Hollow fiber membrane technology reduces bacteria and virus in the water
- 0.85 gpm maximum flow rate at 60 psi
- Filter head automatically turns off water supply when cartridge is removed
- Also sold together with K-77687 as K-29651 Aquifer®+ replacement filter cartridge two-pack



Codes/Standards

CSA B483.1
NSF Protocol P231
NSF/ANSI 42
NSF Protocol P473
NSF/ANSI 401
NSF/ANSI 53
NSF/ANSI 42|NSF/ANSI 53|NSF/ANSI 401|NSF Protocol P231|NSF
Protocol P473

Technical Information

All product dimensions are nominal.

Flow Rate

Faucet Flow Rate: 0.85 gpm (3.2 l/min)

Material

- High-impact plastic construction
-

Warranty

See website for detailed warranty information.

KOHLER® One-Year Limited Warranty



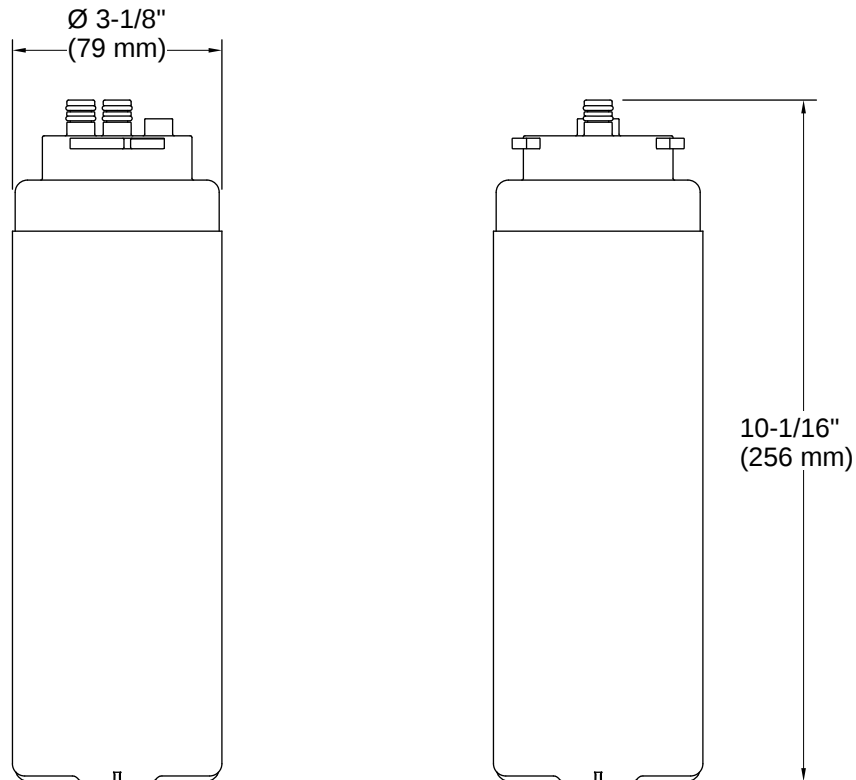

Installation

- Under-sink
- Quarter-turn twist cartridge for easy installation and replacement
- For cold water use only

Installation Notes

Install this product according to the installation instructions.

To prevent the risk of property damage, protect from freezing.
For cold water use only.

To ensure the filter continues to reduce contaminants effectively, it is recommended that the filter gets replaced every 6 months.

Application guideline/water supply parameters: Water Pressure: 40-120 psi (276-827 kPa) Water Temperature: 33-100°F (0.5-37.8°C)

Capacity: 389 gal (1,472 L)



1-800-4KOHLER (1-800-456-4537)

Kohler Co. reserves the right to make revisions without notice to product specifications.
For the most current specification sheet, go to www.kohler.com USA or www.kohler.ca Canada.

4-15-2026 6:3 - US-CA