

Components® | K-103M37-SANA

Touchless single-hole lavatory faucet with Kinesis® sensor technology and temperature mixer, AC-powered, 0.5 gpm

Features

- Kinesis® technology with concealed sensor allows for a clean aesthetic and provides extraordinarily accurate and reliable actuation in varying installation environments
- Below-counter valving reduces the faucet footprint and provides easier service
- Design-forward aesthetic for commercial bathroom spaces
- 0.5 gpm (1.9 lpm) maximum flow rate
- Requires single or multiple AC adapter unit (sold separately)
- On-demand usage with 30-second max. continual run cycle to prevent vandalism and save water
- Vandal-resistant aerator
- 18" (457 mm) stainless steel braided flexible supply hose for easy installation
- Includes spout assembly, grid drain, control box assembly, mechanical mixer, supply hose, and standard mounting hardware
- Complies with the Safe Drinking Water Act (SDWA)



Sustainability



Available Colors/Finishes

Color tiles intended for reference only.

- CP Polished Chrome
- BN Vibrant Brushed Nickel
- BL Matte Black
- 2MB Vibrant Brushed Moderne Brass



Codes/Standards

ADA, OBC, CSA B651 compliant when installed to the specific requirements of these regulations.

ADA CSA B651 OBC

ASME A112.18.1/CSA B125.1
NSF/ANSI/CAN 372
NSF/ANSI/CAN 61
DOE - Energy Policy Act 1992
California Energy Commission (CEC)
ADA
ICC/ANSI A117.1
CSA B651
OBC

Required Electrical Service

One circuit required, protected with Class A Ground-Fault Circuit-Interrupter (GFCI). Outside North America, this device may be known as a Residual Current Device (RCD).

110/220 V, 50 Hz

Warranty

See website for detailed warranty information.

KOHLER® One-Year Limited Warranty

Technical Information

All product dimensions are nominal.

Spout

Spout Reach: 6-5/8" (168 mm)

Flow Rate

Faucet Flow Rate: 0.5 gpm (1.9 l/min)

Valves

Included Valve: Thermostatic Mixer

Material

- Brass construction spout

Technology

- Kinesis® sensor technology offers on-demand detection for maximum water savings



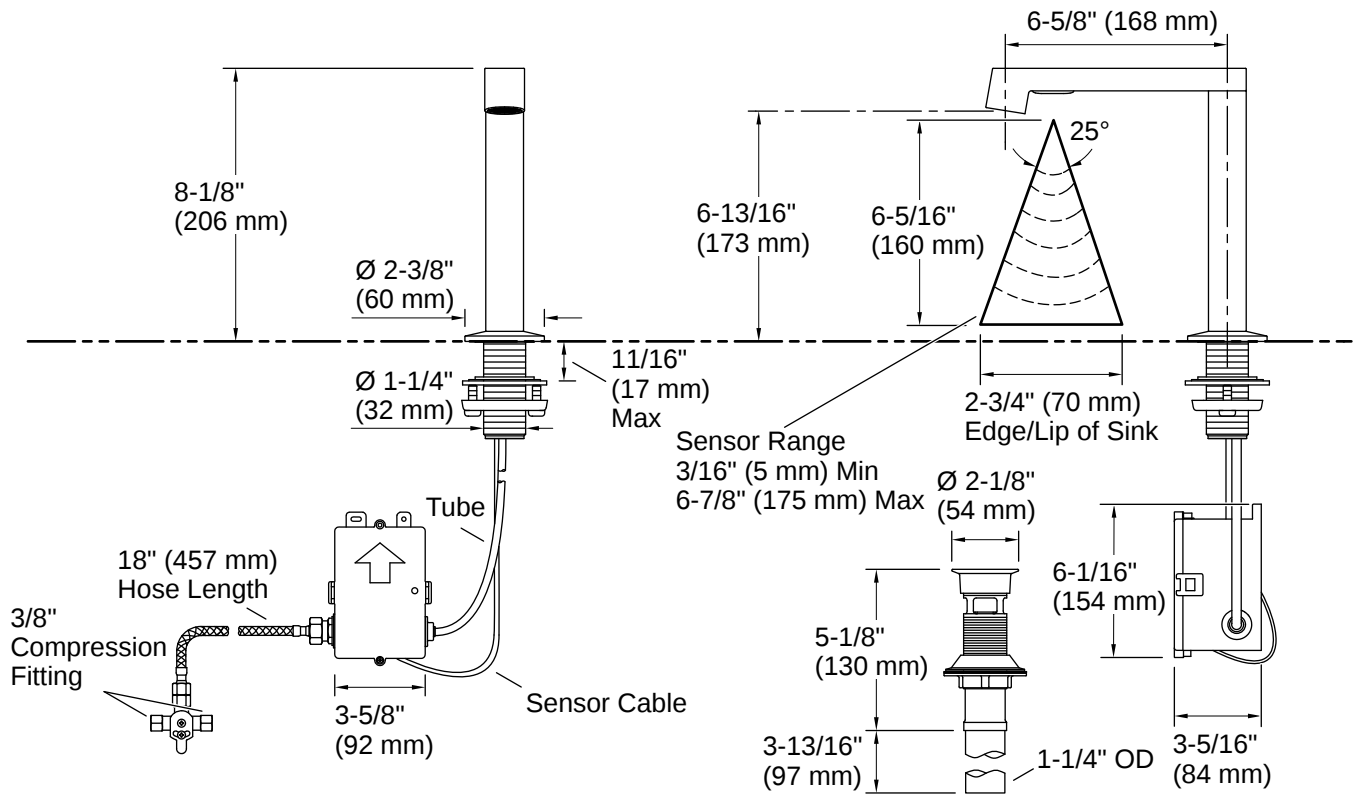

Installation

- Single-hole mounting

Installation Notes

Install this product according to the installation instructions.

ADA, OBC, CSA B651 compliant when installed to the specific requirements of these regulations.

