

Cosmetic mirrors

17612019052 Cosmetic mirror

PRODUCT



DRAWING

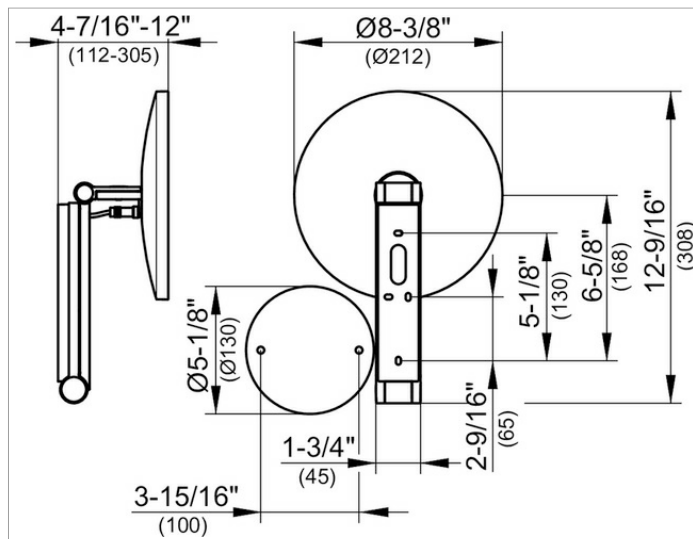

PRODUCT ATTRIBUTES

illuminated, 5-stage adjustable light color from 2700 kelvin (warm white) to 6500 kelvin (daylight), glass control panel, in-wall cable layout, on pivoted arm adjustable in three dimensions, one-sided mirror, magnification factor x 5

Operation:

Glass control panel with capacitive touch sensor and LED display

Power supply:

Connection via hard wire installation, concealed power cable

12 V in-wall adapter, input 110 V, standby consumption: < 0.5 watt

Illumination:

LED 4.5 watt (lifespan > 50.000 hours)

EEK: ,

SPECIFICATIONS

KEUCO iLook_move cosmetic mirror, 17612019052 high quality cosmetic mirror, round, chrome-plated, illuminated with adjustable light color from 2700 kelvin (warm white) to 6500 kelvin (daylight), operated by glass control panel with capacitive touch sensor and LED display on pivoted rail, surface wall-mounted with 4 fixing points for an optimal load distribution adjustable in three dimensions, one-sided mirror, concave magnification factor x 5, Height wall mounting 7-1/8", Width ca. 1-3/4", max. Height ca. 19-11/16", External diameter 8-3/8", max. depth ca. 11-3/4", Power supply via hard wire installation, concealed power cable 12 V in-wall adapter, input 110 V, standby consumption: < 0.5 watt

SURFACE

chrome-plated

Warranty: KEUCO products are covered by a 5-year manufacturer's warranty, in effect from the date of purchase. During this time, proven product defects will be remedied free of charge. Warranty claims must be filed in writing, including a detailed description of the defect immediately after a defect has occurred. For a copy of our detailed product warranty policy, please contact us at office-usa@keuco.com.

Installation: KEUCO products must be installed by a qualified professional in accordance with the respective installation guidelines and any applicable federal / local building codes and regulations.