

Collection Moll
1275801000 Shower basket

PRODUCT

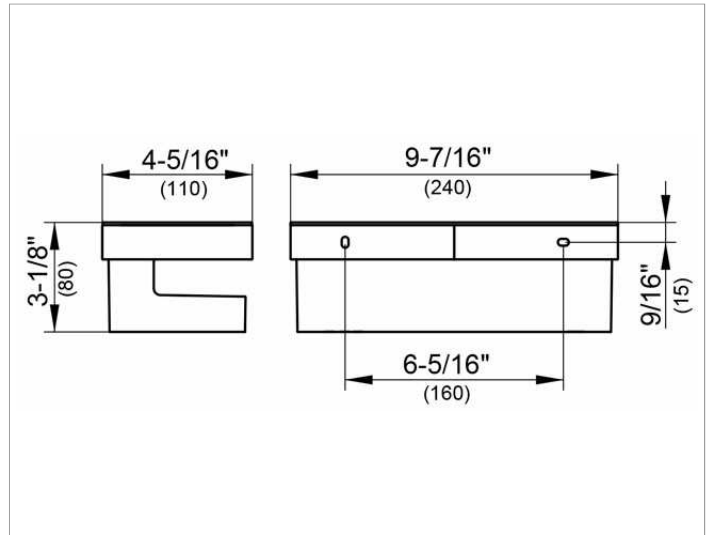

DRAWING



PRODUCT ATTRIBUTES

two parts: metal bracket and detachable synthetic insert, soap resistant, shatterproof, UV-protected

SURFACE

chrome-plated/white

SPECIFICATIONS

KEUCO COLLECTION MOLL shower basket, wall mounted
 1275801000

Chrome-plated metal basket with removable, soap resistant, break-proof and UV-protected, white, easy to clean

Total depth 4-5/16", height 3-1/8", total width 9-7/16"

The shower basket is fitted with 2 hidden fixing points incl. corrosion-free mounting material

Warranty: KEUCO products are covered by a 5-year manufacturer's warranty, in effect from the date of purchase. During this time, proven product defects will be remedied free of charge. Warranty claims must be filed in writing, including a detailed description of the defect immediately after a defect has occurred. For a copy of our detailed product warranty policy, please contact us at office-usa@keuco.com.

Installation: KEUCO products must be installed by a qualified professional in accordance with the respective installation guidelines and any applicable federal / local building codes and regulations.