

Collection Moll
12707010000 Support rail

PRODUCT

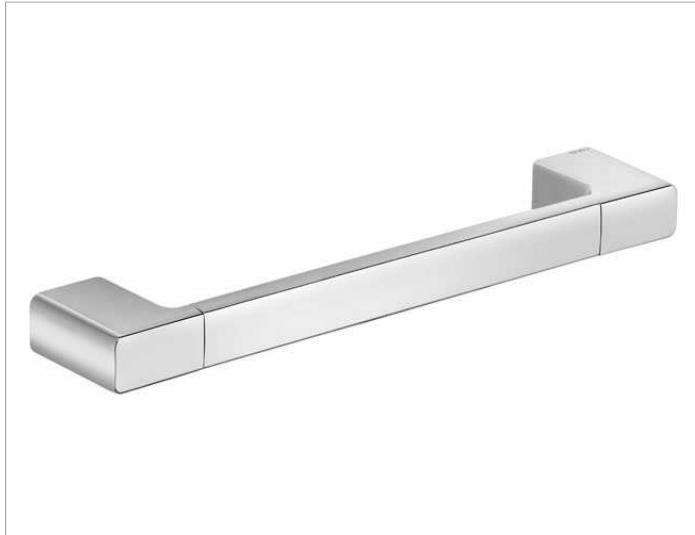

DRAWING

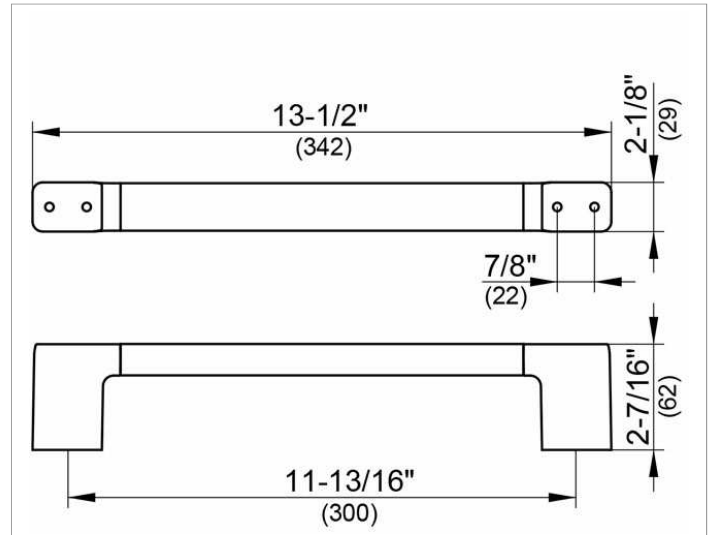

SURFACE

chrome-plated

DIMENSION

11,81 "

SPECIFICATIONS

KEUCO COLLECTION MOLL grab rail 12707010000
 Chrome-plated grab rail, in an esthetic design with slightly rounded edges,
 Load bearing up to 253 lb, anti-static, easy to clean
 Centre to centre 11-13/16" with overall width of 13-1/2"
 Depth 2-7/16"
 The grab rail is fitted with 4 hidden fixing points,
 incl. corrosion-free mounting material

Warranty: KEUCO products are covered by a 5-year manufacturer's warranty, in effect from the date of purchase. During this time, proven product defects will be remedied free of charge. Warranty claims must be filed in writing, including a detailed description of the defect immediately after a defect has occurred. For a copy of our detailed product warranty policy, please contact us at office-usa@keuco.com.

Installation: KEUCO products must be installed by a qualified professional in accordance with the respective installation guidelines and any applicable federal / local building codes and regulations.