

UCR 2 Specifications



UCR 2:

- Universal 2" Ring in ABS - 5 7/8" Diameter x 2" Throat.

- Adapts to Schluter®-KERDI Drain Flange.

For use with 4"x 4" center drains

(Pro-Series and Premium Series).

- Allows clamping to standard drain bodies.

Works with 2" threaded nipple TNAS or S50 in S Series, FX 65 Series & FCB Series products, and all standard flow center drains.

(Not rated for hot mop)

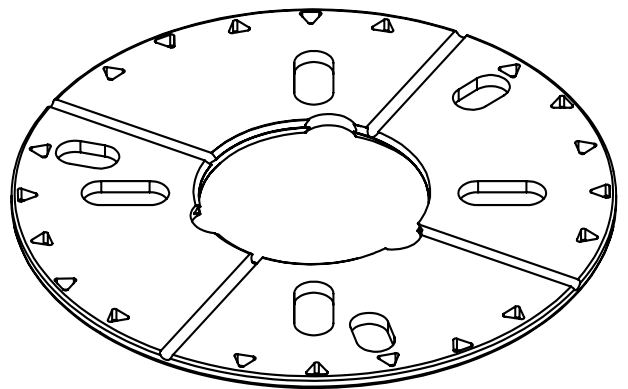
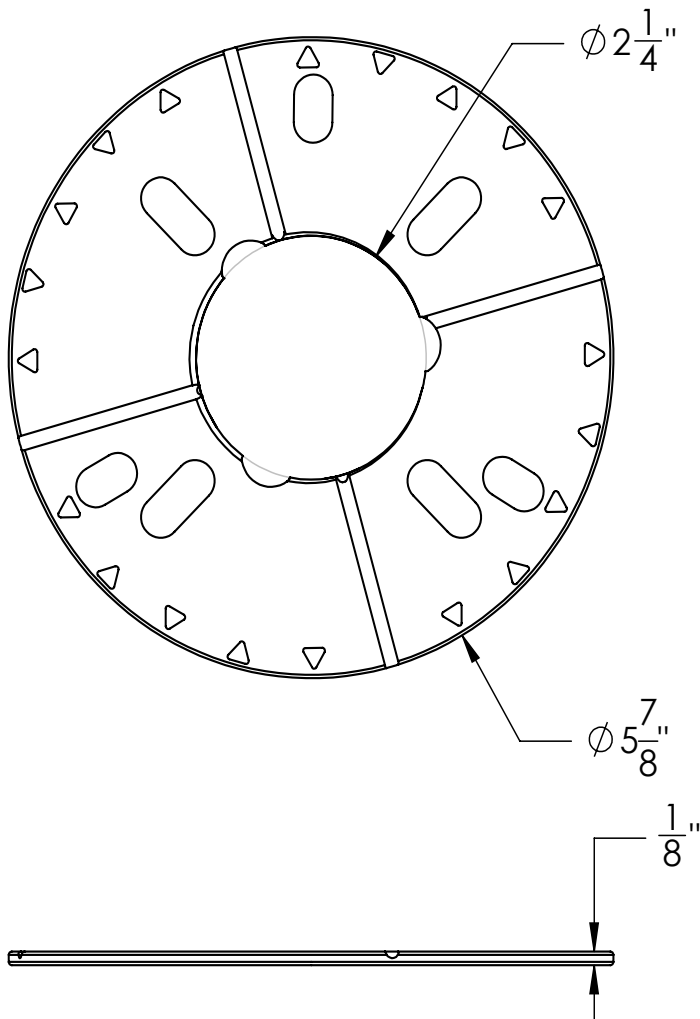

Infinity Drain
145 Dixon Avenue
Amityville, NY 11701
Phone: 516.767.6786
Fax: 516.740.3066
www.infinitydrain.com



NOTE: Installer must verify all rough-in dimensions prior to installation and consult local and national codes. Conformity and compliance to local and national codes are the responsibility of the installer.