

## Product Features

- 90° Ceramic cartridges
- 1/2" high capacity valves
- Secuflex™ watertight hose system
- Includes Secubox™
- Max. flow rate 10 gpm @ 44 psi
- Protection against back siphonage provided by check valve (included with trim kit)

## Code Compliance

This unit meets or exceeds the following:

- ASME A112.18.1
- CSA B125.1
- Listed by IAPMO

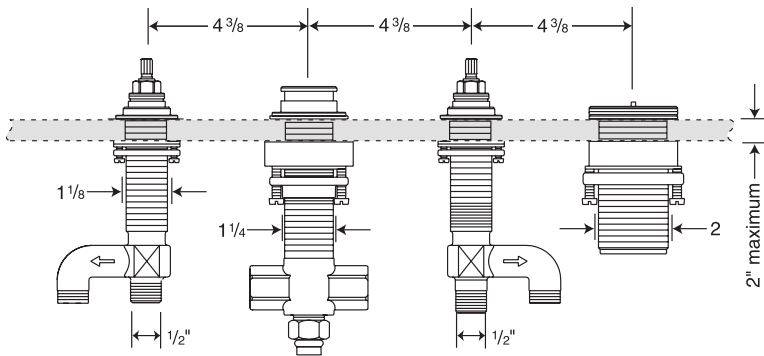

## Required Accessories

Trim kit – many styles available

## Optional Accessories

In-line pressure balance valve  
if required by local code

13418181

## Installation Notes

- For best results, use template included. Custom installations may require additional parts, which are not available from Hansgrohe.
- Requires 1/2" supply lines

The measurements shown are for reference only.

Products and specifications shown are subject to change without notice.

Specification sheet revised 11/2007